

↓ **Pendulum hoist** ↑  
**The hoist for kernmantle rope**



**G-smartrac®**

High Access System technology from goracon

Little Helper. **Gigantic Effect!**

goracon's new **G-smartrac® load hoist for material transport** makes working up high economic and simple.



## The "little one" has a big effect!

**G-smartrac® material rope traction hoist with electric motor for material transport.**

Do you have time to waste? Of course not. Wasted time means unnecessary costs and lost profits!

How the **G-smartrac®** works:  
 Mobile motorized rope hoist with adjustable lifting height for flexible and economic assembly use. Simple operation for working safely on high. This is a material rope traction hoist which drives a sheathed rope without rolling it up. This means any height can be reached.

Electronic overload monitoring prevents lift operations from being overloaded, giving your hoist a long service life without wear.

Please contact us for further information or technical details!



2

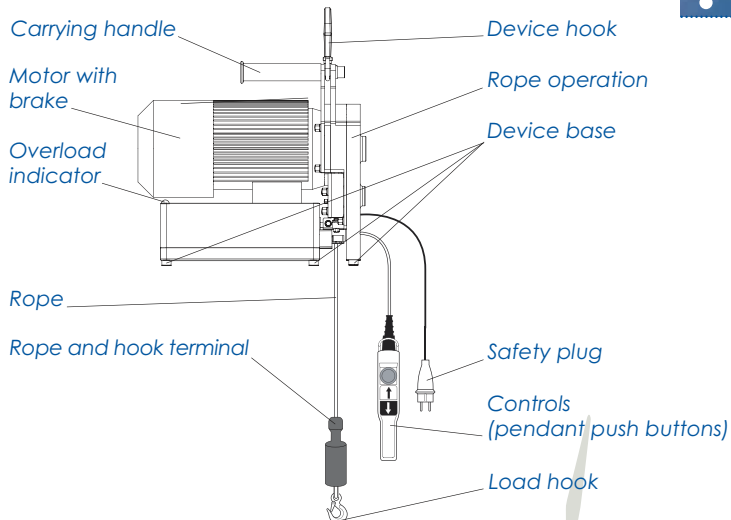

### ! Must be on every construction site

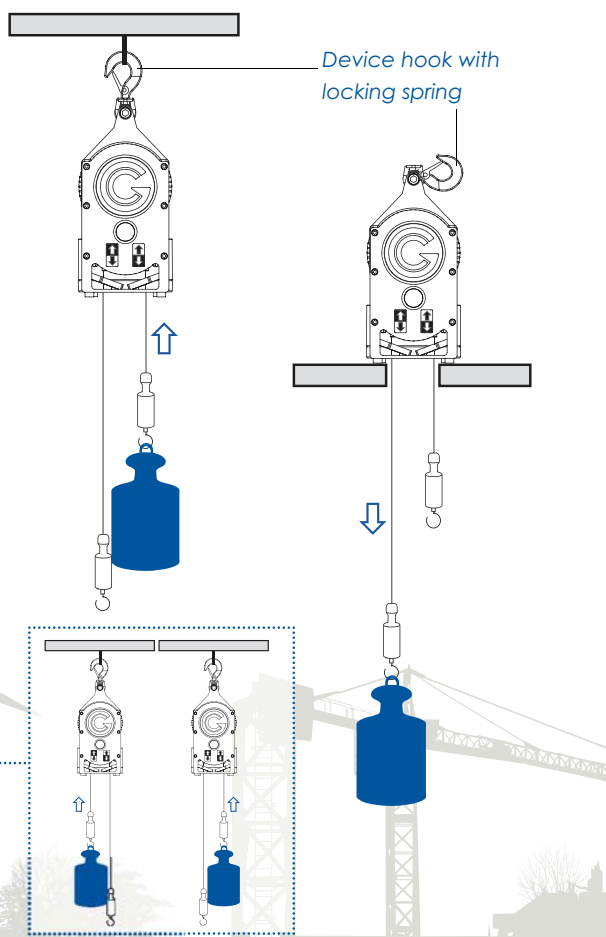

↑ ↓ **pendular load lift in both directions possible** ↑ ↓

Your benefits compared with similar hoisting gear:

- The **G-smartrac**® pendulum hoist (pendular load lift in both directions possible) allows you to achieve 50% cost reductions! The pendulum hoist rules out unloaded operations and is ready to go in no time.
- At 22 kg, the **G-smartrac**® is a lightweight!
- With a top speed of 30 m/min exceeded by none, the **G-smartrac**® is the number one!
- With 120 kg load capacity, the **G-smartrac**® is a Hercules of its class!
- As the **G-smartrac**® operates with 230 V alternating current, it can be used anywhere!
- Flexible and light sheathed ropes made of synthetic fibers (available in all lengths)
- Quickly available with safety hook
- Simple one-hand operation using control strip
- Height restriction in both directions using stop button
- Low-maintenance!

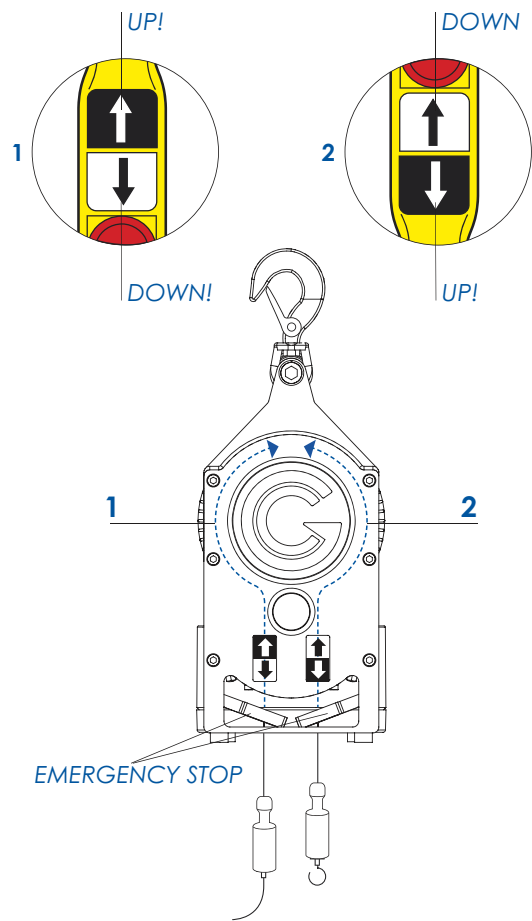

Optional accessories\*

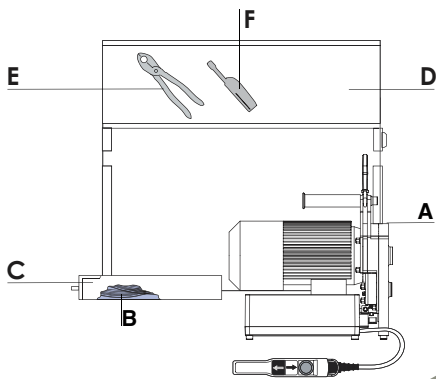

**G-smartrac**®

**MK 120830 type\*\***

Load capacity	120 kg
Rope speed	30 m/min
Voltage	230 V - alternating current
Output	0.75 kW
rated current	approx. 5.6 A
Self weight	22 kg
goracon rope	Polyester with sheath
Diameter	8.0 mm
Necessary electr. output in generator operation	> 2.0 kW

\*Optional accessories:  
G-bag (C), G-case (D), Rope end pliers (E), rope end burner (F)

\*\* We reserve the right make alteration to the Produkt program without prior notice. No liability for mistaken or printing errors with regards to product images and product descriptions. Our terms of conditions apply.



The sky's our limit!

